

KOMATSU

PC130-8

ENGINE POWER
72,0 kW / 96,6 HP @ 2.200 rpm

OPERATING WEIGHT
12.800 - 13.485 kg

BUCKET CAPACITY
max. 0,8 m³

PC
130

HYDRAULIC EXCAVATOR



PC130-8

ecot3

WALK-AROUND

A unique machine with unrivalled benefits

The PC130-8 is a rugged, productive, all-European machine. Designed and expressly built for European markets, it delivers outstanding productivity, reliability and operator comforts in a robust, environmentally friendly package. Komatsu's exclusive, on-board, HydraMind system assists in all operations, providing enhanced machine performance that's always perfectly matched to the task.

Effective fuel management

Improved fuel consumption

Through total Komatsu development and control of the engine, hydraulic and electrical systems.



Revolutionary machine management

Track and monitor your machine anytime, anywhere for total peace of mind.

KOMTRAX

Total operator comfort

Low-noise cab

Operator ear noise is as low as an average passenger car.

Large TFT monitor

Improved operator interface through Komatsu-developed information technology.

(TFT: Thin Film Transistor)

ENGINE POWER

72,0 kW / 96,6 HP @ 2.200 rpm

OPERATING WEIGHT

12.800 - 13.485 kg

BUCKET CAPACITY

max. 0,8 m³

Complete safety

New, safe SpaceCab™

Tubular design developed specifically for hydraulic excavators to protect the operator in the event of a roll over accident.



Protecting the environment

The Komatsu SAA4D95LE-5 engine meets EU Stage IIIA and EPA Tier III emission regulations.

TOTAL OPERATOR COMFORT

Wide, spacious cab

The newly designed, wide and spacious cab includes a heated air suspension seat with reclining backrest. The seat height and longitudinal inclination are easily adjusted using a pull-up lever. You can also set the operational posture of the armrest and the position of the console to suit your needs. Reclining the seat further enables you to place it into the fully flat state with the headrest attached.

Low-noise design

The newly designed cab is highly rigid and has excellent sound absorption ability. Thorough improvement of the noise source reduction technology and the use of low-noise engine, hydraulic equipment and air conditioner mean this machine generates very low noise levels, similar to that of a passenger car.

Pressurised cab

An air conditioner and air filter are fitted as standard. Together with a higher internal air pressure (60 Pa), they reduce dust entry into the cab.

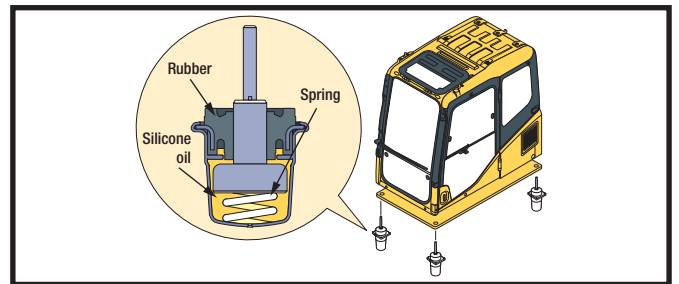

Low vibration with cab damper mounting

A multi-layer viscous mount system incorporates a longer stroke and the addition of a spring. The new cab damper mounting combined with a high-rigidity deck reduces vibration at the operator's seat.

Reduced noise levels

Reduced noise levels during operation due to low-noise engine and other developments.

- Electronically controlled common rail engine
- Multi-staged injection
- Partition between the cab and engine room
- Optimal arrangement of sound-absorbing materials





Automatic air conditioner

Joysticks with proportional control button for attachments



Additional working lamps (option)

Hot and cool box



Quick-coupler piping standard

Bottle holder and magazine rack



Large sun roof with integrated sun shade

12 Volt power supply



Outer air filter
Easy removal/installation of the air conditioner filter element, without tools facilitates cleaning.

Radio



TOTAL OPERATOR COMFORT

New, large TFT monitor

EMMS (Equipment Management and Monitoring System)

The EMMS is a highly sophisticated system, controlling and monitoring all the excavator functions. The user interface is highly intuitive and provides the operator with easy access to a huge range of functions and operating information.

Large multi-lingual TFT monitor

A large user-friendly color monitor enables safe, accurate and smooth work. Screen visibility is improved through a TFT liquid crystal display that can be easily read at various angles and in various lighting conditions.

- Simple and easy-to-operate switches
- Industry first function keys facilitate multi-function operations
- Displays data in 10 languages to support operators around the world

On-screen symbols

- 1 Auto deceleration
- 2 Working mode
- 3 Travel speed
- 4 Engine water temperature gauge
- 5 Hydraulic oil temperature gauge
- 6 Fuel level gauge
- 7 Eco-gauge
- 8 Function switch menu

Basic operation switches

- 1 Auto deceleration
- 2 Working mode
- 3 Travel speed
- 4 Buzzer cancel
- 5 Window wiper
- 6 Window washer



Working mode	Application	Advantage
P	Power mode	<ul style="list-style-type: none"> • Maximum production/power • Fast cycle times
E	Economy mode	<ul style="list-style-type: none"> • Excellent fuel economy
B	Breaker mode	<ul style="list-style-type: none"> • Optimum engine RPMs and hydraulic flow
L	Lifting mode	<ul style="list-style-type: none"> • Hydraulic pressure has been increased by 7%
ATT	Attachment mode	<ul style="list-style-type: none"> • Optimum engine RPMs, hydraulic flow, 2 way



Monitor function

The controller monitors engine oil level, coolant temperature, battery charge and air clogging, etc. If the controller finds any abnormality, it is displayed on the LCD.



Maintenance function

The monitor indicates when the replacement interval has been reached for the oil and filters.



Fingertip hydraulic pump oil flow adjustment

From the LCD monitor, you can automatically select the optimal hydraulic pump oil flow for breaking, crushing and other operations in the B and ATT modes. In addition, the flow to the attachment is automatically reduced during simultaneous operation with other working equipment. This ensures smooth motion of all working equipment. Hydraulic pump oil flow adjustment for both attachment lines is now possible.



EFFECTIVE FUEL MANAGEMENT

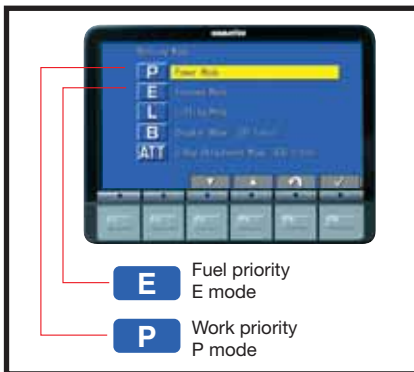

Working modes

Two established work modes are further improved.

P mode - Power or work priority mode has low fuel consumption, but fast equipment speed, maximum production and power are maintained.

E mode - Economy or fuel priority mode further reduces fuel consumption, but maintains P mode-like working speed for light operations.

You can select Power or Economy modes using a one-touch operation on the monitor panel depending on workload.



Eco-gauge assists energy-saving operations

The Eco-gauge can be seen on the right hand side of the monitor. Working within the green range for environmentally friendly, energy-saving operations reduces CO₂ emissions and fuel consumption.



Idle caution

To prevent unnecessary fuel consumption, an idling caution is displayed on the monitor if the engine idles for 5 minutes or more.

Reliable components

All of the major machine components (such as the engine, hydraulic pump, hydraulic motor and control valves) are designed and manufactured by Komatsu. This guarantees that each component is expressly built for the class and model of machine. This ensures that the engineering, manufacturing standards and testing that go into each component are 'totally Komatsu'.

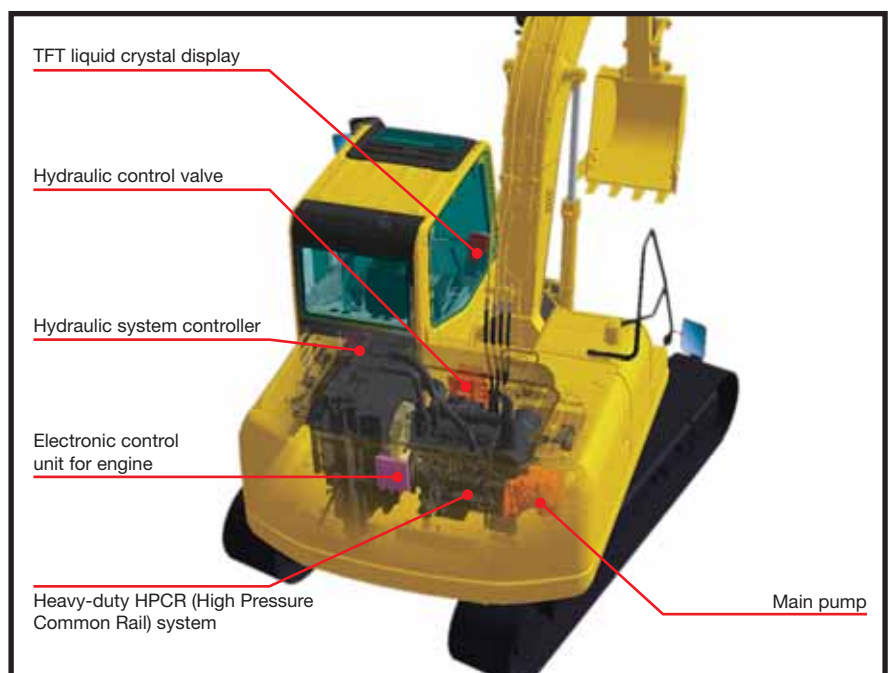

PROTECTING THE ENVIRONMENT

New ECOT3 engine



The new PC130-8 offers up to 10% fuel savings over Dash 7 machines

With its newly developed Komatsu ECOT3 engine, the PC130-8 significantly reduces hourly fuel consumption through highly efficient techniques for matching the engine and hydraulic unit. It also includes a number of features to promote energy-saving operation such as the variable E mode and Eco-gauge.

The Komatsu SAA4D95LE-5 engine meets EPA Tier III, and EU Stage IIIA emissions regulations and reduces NOx emissions.

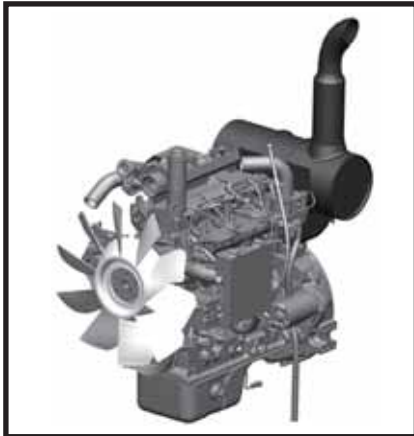

Komatsu SAA4D95LE-5

Easy end-of-life recycling

The PC130-8 is designed with the consideration of end-of-life recycling, effectively reducing its environmental impact.

- All exterior parts are made of steel.
- Extended engine oil, hydraulic oil and filter replacement intervals reduce environmental impact.
- All plastic parts are given a material code symbol.



REVOLUTIONARY MACHINE MANAGEMENT



The Komatsu Tracking System, KOMTRAX™, provides a revolutionary new way to monitor your equipment, anytime, anywhere. It lets you pin-point the precise location of your machines and obtain real-time machine data. Using GPS location and communication satellite technology, it's designed to be future proof and will meet your demands today and tomorrow.

Komtrax will help you to answer the three most important questions you have about your machine:

- Is the machine making money
- Is the machine safe
- Is the machine in good health

For more details, please ask your distributor for a copy of the Komtrax brochure.



KOMTRAX™ server

Check machine location



Customer



Check service meter



Annual working hour record

Machine ID	Year	Working Hours	Fuel Consumption	Other Data
1001	2010	1200	15000	...
1002	2010	1100	14000	...
1003	2010	1300	16000	...

Caution and periodic maintenance

Machine ID	Maintenance Type	Date	Status
1001	Oil Change	2010-01-15	Completed
1001	Filter Replacement	2010-02-01	Completed
1002	Inspection	2010-03-10	Pending

Working record (fuel level, hours etc.)

Date	Working Hours	Fuel Level	Machine ID
2010-01-01	100	100%	1001
2010-01-02	120	95%	1001
2010-01-03	110	90%	1001

There are certain countries where KOMTRAX™ is not yet available, please contact your distributor when you want to activate the system. Komtrax will not operate if the satellite signal is blocked or obscured.

COMPLETE SAFETY

New, safe SpaceCab™

Specifically developed for Komatsu excavators, the new cab is designed with a tubular steel frame. The framework provides high durability and impact resistance with very high impact absorbancy. The seat belt keeps the operator in the safety zone of the cab in the event of a roll over.

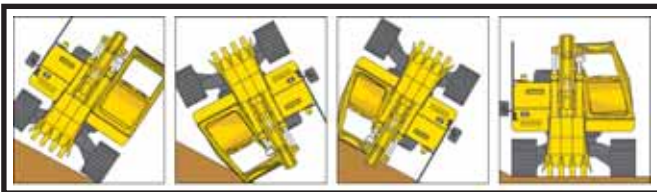

Rear view camera system standard

Lock lever

Locks the hydraulic pressure to prevent unintentional movement. Neutral start function only allows machine to be started in lock position.



Anti-slip plates

Highly durable anti-slip plates maintain superior traction performance for the long term.

Arm safety valve

(optional)



Thermal and fan guards

Placed around high-temperature parts of the engine. The fan belt and pulleys are well protected.



Large side-view, rear, and sidewise mirrors

Enlarged left-side mirror and addition of rear and side mirror allow the machine to meet the new ISO visibility requirements.

Pump/engine room partition

Prevents hydraulic oil from spraying onto the engine to reduce the risk of fire.

Audible travel alarm

MAINTENANCE FEATURES

Side-by-side cooling

Since the radiator, aftercooler and oil cooler are arranged in parallel, it is easy to clean, remove and install them.



Easy access to the engine oil filter and fuel drain valve

The engine oil filter and fuel drain valve are mounted remotely to improve accessibility.



Auto shut-off refuel pump

The new auto shut-off refuel pump prevents fuel spills onto hot or electrical areas, and prevents wasting fuel.



Water separator

This is standard equipment which removes any water that has become mixed with the fuel, preventing fuel system damage.



Washable floor

The floor is easy to keep clean. The gently inclined surface has a flanged floormat and drainage holes to facilitate runoff.

Inclined track frame

The track frame is sloped so that dirt will not accumulate and can be removed easily.

Long-life oil filters

The hydraulic oil filter uses high-performance filtering material for long element replacement intervals, which significantly reduces maintenance costs.



Flexible warranty

When you purchase Komatsu equipment, you gain access to a broad range of programmes and services that have been designed to help you get the most from your investment. For example, Komatsu's Flexible Warranty Programme provides a range of extended warranty options on the machine and its components. These can be chosen to meet your individual needs and activities. This programme is designed to help reduce total operating costs.

SPECIFICATIONS



ENGINE

ModelKomatsu SAA4D95LE-5
 TypeCommon rail direct injection, water-cooled, emissionised, turbocharged, after-cooled diesel

Engine power
 at rated engine speed2.200 rpm
 ISO 1439672,0 kW / 96,6 HP
 ISO 9249 (net engine power)68,4 kW / 91,7 HP

No. of cylinders 4
 Bore x stroke95 x 115 mm
 Displacement3,26 ltr
 Battery 2 x 12 V/92 Ah
 Alternator 24 V/60 A
 Starter motor24 V/4,5 kW
 Air filter type Double element type with monitor panel dust indicator and auto dust evacuator
 CoolingSuction type cooling fan with radiator fly screen



HYDRAULIC SYSTEM

TypeHydrauMind. Closed-centre system with load sensing and pressure compensation valves
 Additional circuits 1 additional circuit with proportional control standard, a second additional circuit with proportional control may be fitted optionally
 Main pump variable displacement piston pump supplying boom, arm, bucket, swing and travel circuits
 Maximum pump flow242 ltr/min
 Relief valve settings
 Implement352 bar
 Travel352 bar
 Swing276 bar
 Pilot circuit33 bar



ENVIRONMENT

Engine emissions Fully complies with EU Stage IIIA and EPA Tier III exhaust emission regulations

Noise levels
 LwA external 100 dB(A) (2000/14/EC Stage II)
 LpA operator ear68 dB(A) (ISO 6396 dynamic test)



OPERATING WEIGHT (APPR.)

Operating weight, including specified work equipment, 2.500 mm arm, 0,5 m³ bucket, operator, lubricant, coolant, full fuel tank and the standard equipment.



SWING SYSTEM

Type Axial piston motor driving through planetary double reduction gearbox
 Swing lock Electrically actuated wet multi-disc brake integrated into swing motor
 Swing speed 0 - 11 rpm
 Swing torque32,9 kNm



DRIVES AND BRAKES

Steering control 2 levers with pedals giving full independent control of each track
 Drive methodHydrostatic
 Travel operation Automatic 2-speed selection
 Gradeability 70%, 35°
 Max. travel speeds
 Lo / Hi2,9 / 5,5 km/h
 Maximum drawbar pull 12.500 kgf
 Brake system Hydraulically operated discs in each travel motor



UNDERCARRIAGE

Construction X-frame centre section with box section track-frames

Track assembly
 Type Fully sealed
 Shoes (each side) 43
 Tension Combined spring and hydraulic unit

Rollers
 Track rollers (each side) 7
 Carrier rollers (each side) 1



COOLANT AND LUBRICANT CAPACITY (REFILLING)

Fuel tank247 ltr
 Radiator 13,9 ltr
 Engine oil 11 ltr
 Swing drive 2,5 ltr
 Hydraulic tank 90 ltr
 Final drive (each side) 2,5 ltr

	MONO BOOM		TWO-PIECE BOOM	
	Operating weight	Ground pressure	Operating weight	Ground pressure
Triple grouser shoes				
500 mm	12.800 kg	0,41 kg/cm ²	13.125 kg	0,42 kg/cm ²
600 mm	12.980 kg	0,34 kg/cm ²	13.305 kg	0,35 kg/cm ²
700 mm	13.160 kg	0,30 kg/cm ²	13.485 kg	0,31 kg/cm ²

Additional weight with 500 mm road-liner: + 130 kg
 Additional weight with blade: + 900 kg

MACHINE DIMENSIONS

MACHINE DIMENSIONS		PC130-8
A	Overall width of upper structure	2.500 mm
B	Overall height of cab	2.855 mm
C	Overall length of basic machine	3.925 mm
D	Tail length	2.110 mm
	Tail swing radius	2.190 mm
E	Clearance under counterweight	895 mm
F	Machine tail height	2.190 mm
G	Ground clearance	400 mm
H	Tumbler center distance	2.880 mm
I	Track length	3.610 mm
J	Track gauge	1.990 mm
K	Track shoe width	500; 600; 700 mm
L	Overall track width with 500 mm shoe	2.490 mm
	Overall track width with 600 mm shoe	2.590 mm
	Overall track width with 700 mm shoe	2.690 mm

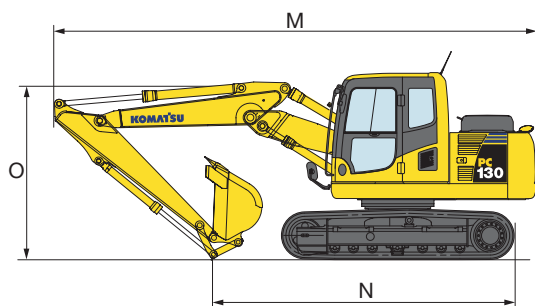
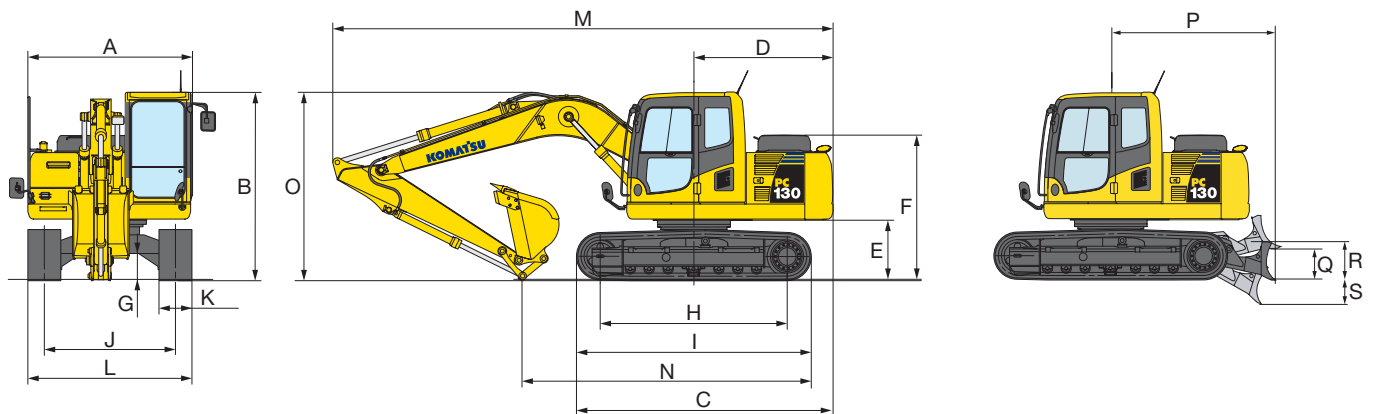

BLADE		
P	Distance, swing center to blade	2.490 mm
Q	Height of blade	590 mm
R	Blade, max. lifting height	470 mm
S	Blade, max. digging depth	525 mm
	Blade width	2.590 mm

TRANSPORT DIMENSIONS	MONO BOOM			TWO-PIECE BOOM			
	Arm length	2.100 mm	2.500 mm	3.000 mm	2.100 mm	2.500 mm	3.000 mm
M	Transport length	7.600 mm	7.590 mm	7.485 mm	7.425 mm	7.360 mm	7.220 mm
N	Length on ground (transport)	4.670 mm	4.410 mm	4.280 mm	4.800 mm	4.610 mm	4.270 mm
O	Overall height (to top of boom)	2.600 mm	2.875 mm	3.185 mm	2.545 mm	2.710 mm	3.095 mm



BUCKET OPTIONS & DIGGING FORCES

Specifications and equipment may vary according to regional availability

BUCKET AND ARM COMBINATION			ARM LENGTH		
Capacity SAE	Width	Weight	2.100 mm	2.500 mm	3.000 mm
0,25 m ³	500 mm	335 kg	○	○	○
0,32 m ³	600 mm	375 kg	○	○	○
0,4 m ³	700 mm	390 kg	○	○	○
0,48 m ³	800 mm	470 kg	○	○	○
0,56 m ³	900 mm	475 kg	○	○	□
0,64 m ³	1.000 mm	505 kg	○	□	□
0,72 m ³	1.100 mm	560 kg	□	△	△
0,8 m ³	1.200 mm	620 kg	△	–	–

Please consult with your distributor for the correct selection of buckets and attachments to suit the application. The recommendations are given as a guide only, based on typical operating conditions.

- Material weight up to 1,8 t/m³
- Material weight up to 1,5 t/m³
- △ Material weight up to 1,2 t/m³
- Not usable

A full range of Komatsu wear parts is available.

A wide range of attachments is available. Please consult your distributor for details of the full range.



BUCKET AND ARM FORCE			
Arm length	2.100 mm	2.500 mm	3.000 mm
Bucket digging force	8.800 kgf	8.800 kgf	8.800 kgf
Bucket digging force at PowerMax	9.500 kgf	9.500 kgf	9.500 kgf
Arm crowd force	7.200 kgf	6.300 kgf	5.700 kgf
Arm crowd force at PowerMax	7.900 kgf	6.900 kgf	6.200 kgf

WORKING RANGE

MONO BOOM

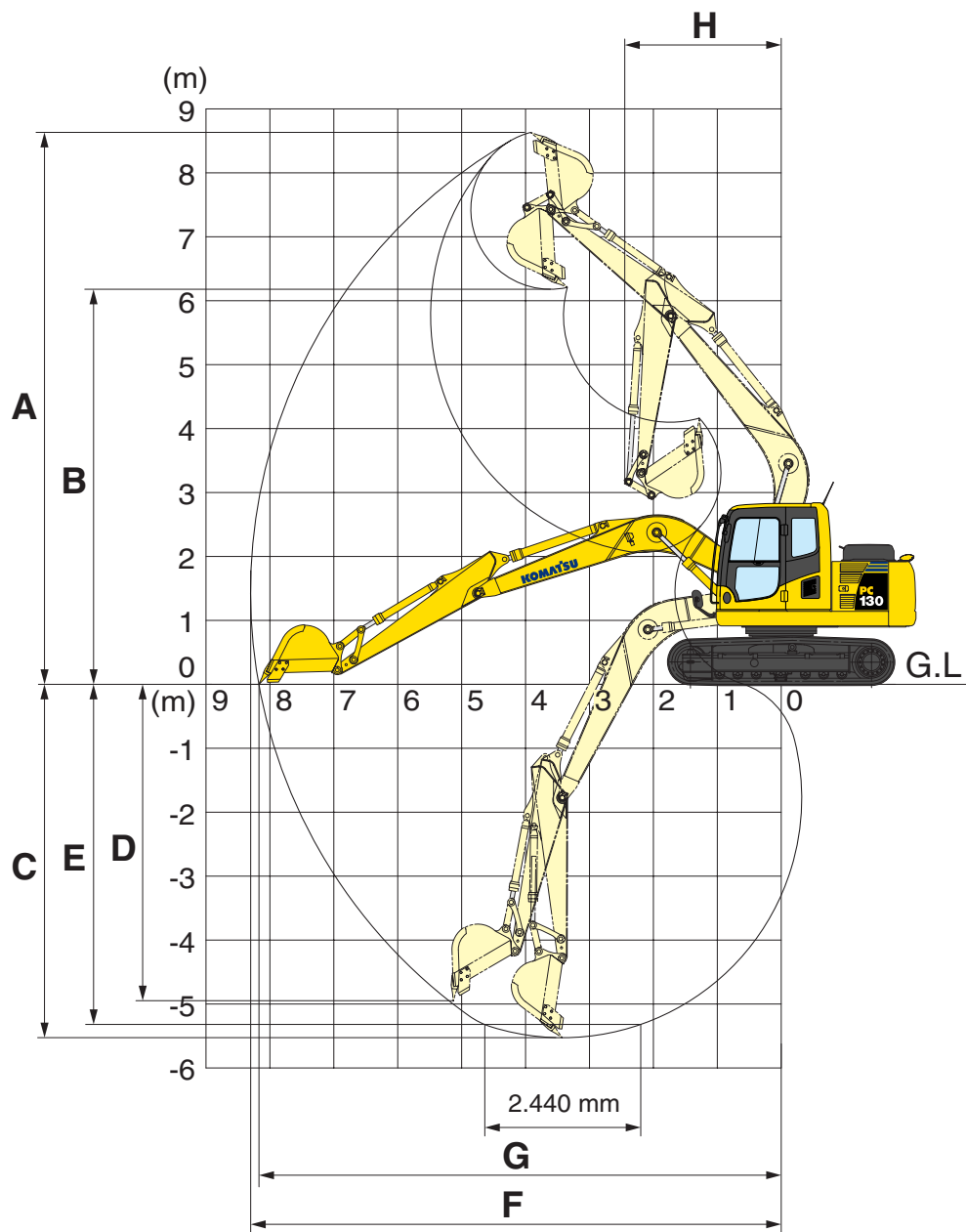

WORKING RANGE		MONO BOOM		
	Arm length	2.100 mm	2.500 mm	3.000 mm
A	Max. digging height	8.390 mm	8.650 mm	8.930 mm
B	Max. dumping height	5.935 mm	6.210 mm	6.615 mm
C	Max. digging depth	5.125 mm	5.520 mm	5.955 mm
D	Max. vertical wall digging depth	4.570 mm	4.980 mm	5.365 mm
E	Max. digging depth of cut for 2,44 m level	4.870 mm	5.320 mm	5.775 mm
F	Max. digging reach	7.930 mm	8.290 mm	8.720 mm
G	Max. digging reach at ground level	7.795 mm	8.170 mm	8.595 mm
H	Min. swing radius	2.410 mm	2.450 mm	2.610 mm

TWO-PIECE BOOM

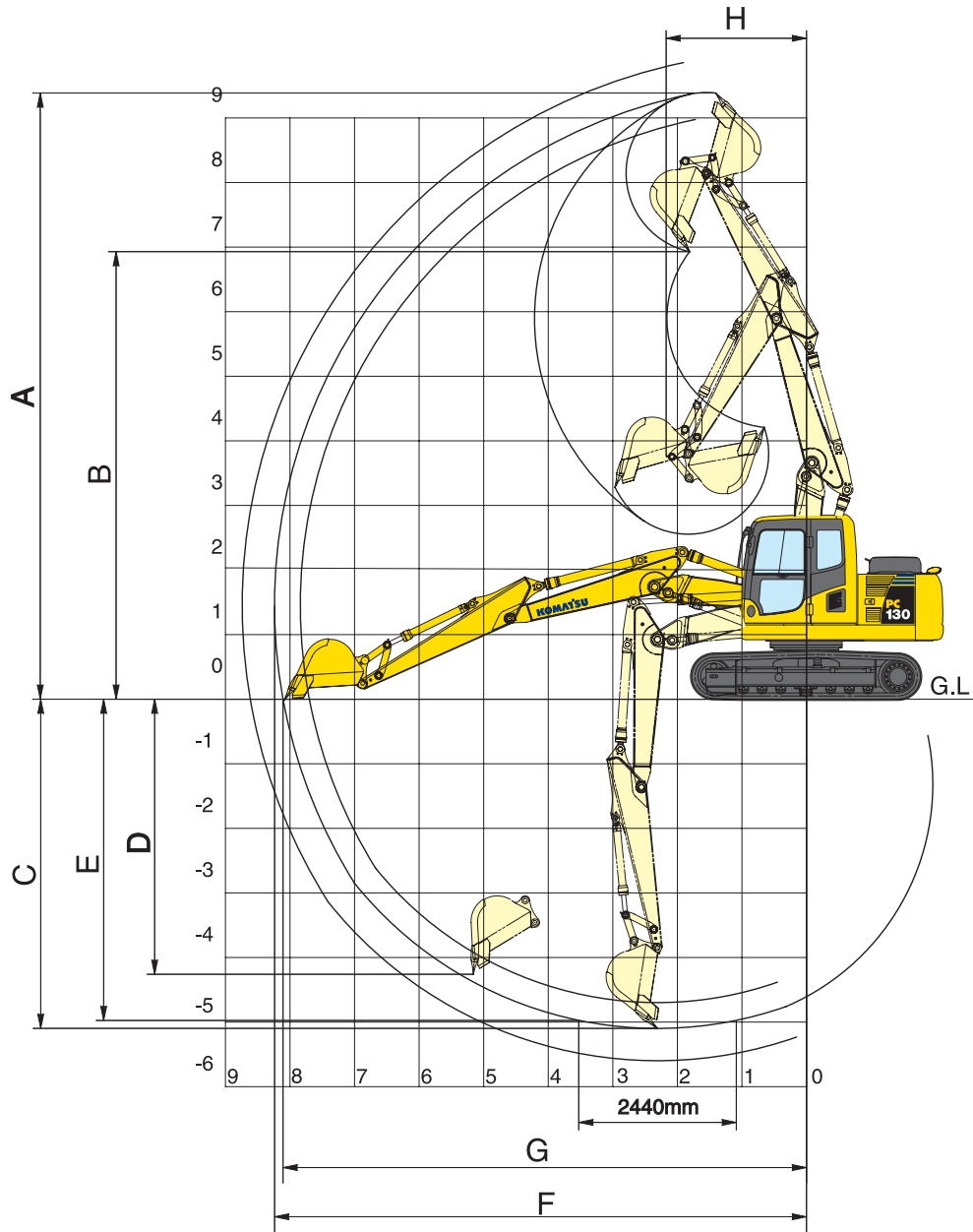





WORKING RANGE		TWO-PIECE BOOM		
	Arm length	2.100 mm	2.500 mm	3.000 mm
A	Max. digging height	9.120 mm	9.490 mm	9.955 mm
B	Max. dumping height	6.670 mm	7.045 mm	7.510 mm
C	Max. digging depth	4.705 mm	5.105 mm	5.605 mm
D	Max. vertical wall digging depth	3.920 mm	4.260 mm	4.770 mm
E	Max. digging depth of cut for 2,44 m level	4.535 mm	5.000 mm	5.505 mm
F	Max. digging reach	7.895 mm	8.285 mm	8.775 mm
G	Max. digging reach at ground level	7.755 mm	8.155 mm	8.650 mm
H	Min. swing radius	1.955 mm	2.150 mm	2.500 mm

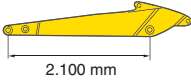

LIFTING CAPACITY

MONO BOOM

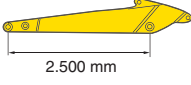
Arm length	A B	⊗		7,5 m		6,0 m		4,5 m		3,0 m		1,5 m	
		🔧	🔗	🔧	🔗	🔧	🔗	🔧	🔗	🔧	🔗	🔧	🔗

With 700 mm shoe  2.100 mm  469 kg	6,0 m	kg	*2.400	*2.400					*3.400	*3.400			
	4,5 m	kg	*2.250	2.000			2.950	2.200	*3.550	*3.550			
	3,0 m	kg	*2.250	1.700			2.950	2.150	*4.350	3.450	*6.000	*6.000	
	1,5 m	kg	2.200	1.550			2.850	2.050	4.550	3.250	*8.550	6.000	
	0,0 m	kg	2.250	1.600			2.750	2.000	4.250	3.050	*7.400	5.650	
	-1,5 m	kg	2.550	1.800			2.750	1.950	4.150	3.000	8.750	5.600	*4.750 *4.750
	-3,0 m	kg	3.300	2.350					4.300	3.000	*7.550	5.750	*8.800 *8.800
	-4,5 m	kg											

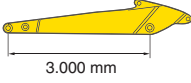
With 700 mm shoe  2.500 mm  469 kg	6,0 m	kg	*1.950	*1.950									
	4,5 m	kg	*1.800	1.700			3.000	2.250	*3.150	*3.150			
	3,0 m	kg	*1.850	1.550	2.250	1.650	2.950	2.200	*3.950	3.550	*5.200	*5.200	
	1,5 m	kg	*1.950	1.450	2.200	1.600	2.850	2.100	4.550	3.300	*7.900	6.150	
	0,0 m	kg	2.050	1.450	2.150	1.550	2.750	2.000	4.250	3.000	*8.050	5.700	
	-1,5 m	kg	2.250	1.600			2.700	1.950	4.250	3.000	8.700	5.600	*4.700 *4.700
	-3,0 m	kg	2.850	2.050					4.250	2.950	*8.050	5.700	*7.850 *7.850
	-4,5 m	kg	*3.600	3.200							*5.450	*5.450	

With 700 mm shoe  3.000 mm  469 kg	6,0 m	kg	*1.550	*1.550		*2.200	2.250						
	4,5 m	kg	*1.450	1.450	*1.950	1.650	*2.750	2.250					
	3,0 m	kg	*1.450	1.350	2.200	1.650	2.950	2.200	*3.450	*3.450			
	1,5 m	kg	*1.550	1.250	2.150	1.550	2.800	2.050	*4.550	3.300	*6.800	6.250	
	0,0 m	kg	*1.750	1.250	2.100	1.500	2.700	1.950	4.300	3.050	8.800	5.650	
	-1,5 m	kg	1.950	1.350	2.050	1.450	2.650	1.850	4.050	2.900	8.550	5.450	*4.100 *4.100
	-3,0 m	kg	2.350	1.650			2.600	1.850	4.050	2.900	*8.450	5.500	*6.650 *6.650
	-4,5 m	kg	*3.400	2.450					*4.200	3.000	*6.500	5.650	*10.350 *10.350

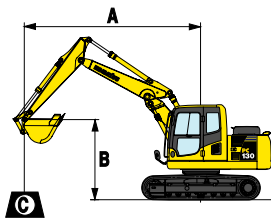
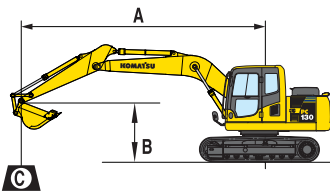

A – Reach from swing centre

B – Bucket hook height

C – Lifting capacities, including bucket (469 kg), bucket linkage (120 kg) and bucket cylinder (83 kg)

🔧 – Rating over front

🔗 – Rating over side

⊗ – Rating at maximum reach

When removing bucket, linkage or cylinder, lifting capacities can be increased by their respective weights

* Load is limited by hydraulic capacity rather than tipping. Ratings are based on SAE Standard No. J1097. Rated loads do not exceed 87% of hydraulic lift capacity or 75% of tipping load.

TWO-PIECE BOOM

Arm length	A	7,5 m		6,0 m		4,5 m		3,0 m		1,5 m	

With 700 mm shoe 469 kg	7,5 m	kg	*3.650	*3.650					*3.850	*3.850		
	6,0 m	kg	*2.600	*2.600			*4.200	3.550	*4.600	*4.600		
	4,5 m	kg	*2.350	2.000			3.050	2.100	*4.800	3.500	*4.150	*4.150
	3,0 m	kg	*2.350	1.650			3.000	2.050	4.950	3.300	*7.900	6.550
	1,5 m	kg	2.300	1.550			2.900	1.950	4.650	3.100		
	0,0 m	kg	2.400	1.550			2.800	1.850	4.450	2.900		
	-1,5 m	kg	*2.600	1.750			2.800	1.850	4.400	2.850	*6.550	5.400
	-3,0 m	kg										
	-4,5 m	kg										

With 700 mm shoe 469 kg	7,5 m	kg	*2.750	*2.750					*4.200	*4.200		
	6,0 m	kg	*2.150	*2.150				*3.850	3.650			
	4,5 m	kg	*1.950	1.800			3.150	2.150	*3.950	3.600	*3.300	*3.300
	3,0 m	kg	*1.900	1.550			3.100	2.100	*5.000	3.400	*6.000	*6.000
	1,5 m	kg	*2.000	1.450			2.950	2.000	4.750	3.150		
	0,0 m	kg	2.200	1.450			2.850	1.900	4.550	2.950	*6.550	5.500
	-1,5 m	kg	2.450	1.600			2.800	1.850	4.400	2.850	*7.400	5.400
	-3,0 m	kg							*3.400	2.900		
	-4,5 m	kg										

With 700 mm shoe 469 kg	7,5 m	kg	*2.200	*2.200				*2.750	*2.750					
	6,0 m	kg	*1.800	*1.800			*2.450	2.250	*3.300	*3.300				
	4,5 m	kg	*1.650	1.600			3.250	2.250	*3.150	*3.150				
	3,0 m	kg	*1.600	1.400	*2.050	1.450	3.150	2.200	*3.750	3.550	*3.100	*3.100		
	1,5 m	kg	*1.700	1.300	2.100	1.400	3.050	2.050	4.900	3.300	*8.650	6.250		
	0,0 m	kg	*1.850	1.300	2.050	1.350	2.900	1.950	4.600	3.050	*7.900	6.650		
	-1,5 m	kg	*2.150	1.450			2.850	1.900	4.450	2.900	*8.250	5.450	*3.100	*3.100
	-3,0 m	kg					*2.400	1.900	*4.150	2.900	*5.900	5.450		
	-4,5 m	kg												

With 500 mm shoe 469 kg	7,5 m	kg	*3.650	*3.650					*3.850	*3.850		
	6,0 m	kg	*2.600	*2.600					*4.200	3.450	*4.600	*4.600
	4,5 m	kg	*2.350	1.950			2.950	2.000	*4.800	3.450	*4.150	*4.150
	3,0 m	kg	*2.350	1.600			2.950	2.000	4.800	3.250	*7.900	6.400
	1,5 m	kg	2.250	1.500			2.800	1.900	4.550	3.000		
	0,0 m	kg	2.300	1.500			2.750	1.800	4.350	2.800		
	-1,5 m	kg	*2.600	1.700			2.700	1.800	4.250	2.750	*6.550	5.250
	-3,0 m	kg										

With 500 mm shoe 469 kg	7,5 m	kg	*2.750	*2.750					*4.200	*4.200		
	6,0 m	kg	*2.150	*2.150					*3.850	3.550		
	4,5 m	kg	*1.950	1.750			3.050	2.100	*3.950	3.550	*3.300	*3.300
	3,0 m	kg	*1.900	1.500			3.000	2.050	4.900	3.350	*6.000	*6.000
	1,5 m	kg	*2.000	1.400			2.900	1.950	4.650	3.100		
	0,0 m	kg	2.150	1.400			2.750	1.850	4.400	2.900	*6.550	5.400
	-1,5 m	kg	2.350	1.550			2.750	1.800	4.300	2.800	*7.400	5.250
	-3,0 m	kg							*3.400	2.800		

With 500 mm shoe 469 kg	7,5 m	kg	*2.200	*2.200					*2.750	*2.750				
	6,0 m	kg	*1.800	*1.800			*2.450	2.200	*3.300	*3.300				
	4,5 m	kg	*1.650	1.550			3.150	2.200	*3.150	*3.150				
	3,0 m	kg	*1.600	1.350	2.050	1.400	3.100	2.100	*3.750	3.450	*3.100	*3.100		
	1,5 m	kg	*1.700	1.250	2.000	1.350	2.950	2.000	4.750	3.200	*8.650	6.100		
	0,0 m	kg	*1.850	1.300	2.000	1.300	2.850	1.900	4.500	2.950	*7.900	5.500		
	-1,5 m	kg	2.100	1.400			2.750	1.850	4.350	2.800	*8.250	5.300	*3.100	*3.100
	-3,0 m	kg					*2.400	1.850	*4.150	2.800	*5.900	5.300		

HYDRAULIC EXCAVATOR

STANDARD EQUIPMENT

- Komatsu SAA4D95LE-5, 72 kW turbocharged common rail direct injection diesel engine, EU Stage IIIA compliant
- Double element type air cleaner with dust indicator and auto-dust evacuator
- Automatic fuel line de-aeration
- Engine key stop
- Alternator 24 V/60 A
- Batteries 2 × 12 V/92 Ah
- Starter motor 24 V/4,5 kW
- Electronic closed-centre load sensing (E-CLSS) hydraulic system (HydraMind)
- Pump and engine mutual control (PEMC) system
- KOMTRAX™ Komatsu Tracking System
- Multi-function video compatible colour monitor with equipment management monitoring system (EMMS) and efficiency guidance
- 5-working mode selection system; Power mode, economy mode, breaker mode, attachment mode and lifting mode
- Standard counterweight
- PowerMax function
- Auto-deceleration function
- Automatic engine warm-up system
- Engine overheat prevention system
- Fuel control dial
- Adjustable PPC wrist control levers with 3 button control and proportional attachment control slider for arm, boom, bucket and swing (suitable for ROTOTILT attachments)
- Hydrostatic, 2-speed travel system with automatic shift and planetary gear type final drives, and hydraulic lock service brakes
- Reinforced safety SpaceCab™; Highly pressurised and tightly sealed hyper viscous mounted cab with tinted safety glass windows, large roof window with sun shade, pull-up type front window with locking device, removable lower window, front window wiper with intermittent feature, sun roller blind, cigarette lighter, ashtray, luggage shelf, floor mat
- Hot and cool box
- Beverage holder and magazine rack
- Heated air suspension seat with adjustable arm rests and retractable seat belt
- Parts book and operator manual
- Lockable fuel cap and covers
- Auto shut-off refuel pump
- Track frame under-guards
- 12 Volt power supply
- Overload warning device
- Boom safety valves
- Automatic climate control system
- Large handrails and rear-view mirrors
- Radio
- Electric horn
- Toolkit and spare parts for first service
- Standard colour scheme and decals
- 500 mm triple grouser track-shoes
- One additional, 2-way proportional service valve (full flow)
- Lights, 2 revolving frame and 1 boom light
- Quick-coupler piping
- Rear view camera system

OPTIONAL EQUIPMENT

- 600 mm; 700 mm triple grouser track-shoes
- 500 mm road-liner track-shoes
- Mono boom
- Two-piece boom
- 2,1 m; 2,5 m; 3,0 m arms
- OPG Level II top guard (FOPS)
- OPG Level II front guard (FOPS)
- Additional (low flow) hydraulic circuit with 2-way proportional control
- Dozer blade
- Additional working lamps, including cab roof lights, r.h. boom lamp, cw rear lamp and beacon
- Rain visor (not with OPG)
- Komatsu buckets
- Arm safety valve
- Komatsu breakers



**Komatsu Europe
International NV**

Mechelsesteenweg 586
B-1800 VILVOORDE (BELGIUM)
Tel. +32-2-255 24 11
Fax +32-2-252 19 81
www.komatsu.eu