

KOMATSU

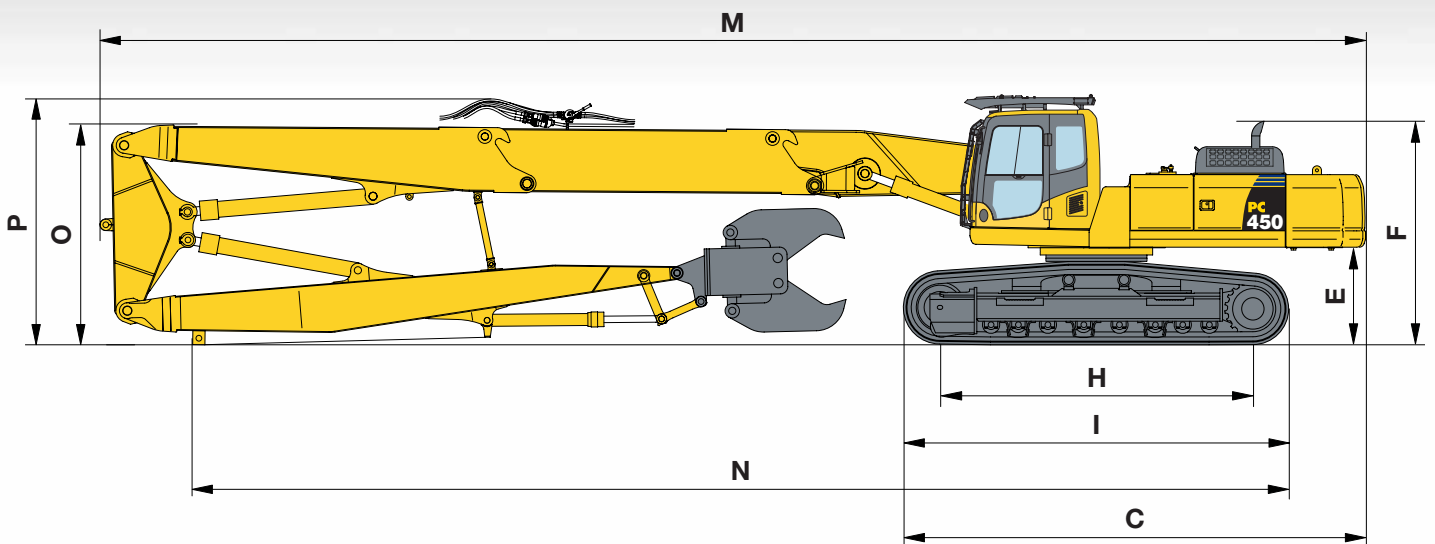

Hydraulic Excavator

PC450LC-8

High Reach Demolition Specification

ENGINE POWER
263 kW / 353 HP @ 1.900 rpm

OPERATING WEIGHT
50.720 - 69.070 kg

ATTACHMENT TOOL WEIGHT
max. 2.500 kg

Specifications

ENGINE

Model Komatsu SAA6D125E-5
 Type..... Common rail direct injection, water-cooled, cooled EGR, emissionised, turbocharged, after-cooled diesel

Engine power
 at rated engine speed 1.900 rpm
 ISO 14396263 kW / 353 HP
 ISO 9249 (net engine power)257 kW / 345 HP

No. of cylinders 6
 Bore x stroke.....125 x 150 mm
 Displacement..... 11,04 ltr
 Battery 2 x 12 V/140 Ah
 Alternator 24 V/60 A
 Starter motor 24 V/11 kW
 Air filter type Double element type with monitor panel dust indicator and auto dust evacuator
 Cooling Suction type cooling fan with radiator fly screen

HYDRAULIC SYSTEM

Type..... HydraMind. Closed-centre system with load sensing and pressure compensation valves

Additional circuits 2 additional circuits are installed

Main pump 2 variable displacement piston pumps supplying boom, arm, bucket, swing and travel circuits

Maximum pump flow..... 2 x 345 ltr/min

Relief valve settings
 Implement380 bar
 Travel.....380 bar
 Swing285 bar
 Pilot circuit33 bar

UNDERCARRIAGE

Construction.....X-frame centre section with box section track-frames

Track assembly
 Type Fully sealed
 Shoes (each side) 49
 Tension.....Combined spring and hydraulic unit

Rollers
 Track rollers (each side) 8
 Carrier rollers (each side)2 (LC); 3 (HWG)

OPERATING WEIGHT (APPR.)

Triple grouser shoes	HIGH REACH		MEDIUM REACH		EXCAVATION BOOM	
	Operating Weight	Ground pressure	Operating Weight	Ground pressure	Operating Weight	Ground pressure
600 mm	58.690 kg	1,11 kg/cm ²	56.970 kg	1,07 kg/cm ²	50.270 kg	0,96 kg/cm ²
700 mm	59.140 kg	0,96 kg/cm ²	57.420 kg	0,93 kg/cm ²	50.720 kg	0,83 kg/cm ²

Operating weight, including specified work equipment. High reach and medium reach includes attachment weight of 2.500 kg. Excavation boom equipment includes 3,4 m arm and 2.180 kg bucket. All include operator, lubricant, coolant, full fuel tank. Optional Hydraulic Wide Gauge (HWG) undercarriage adds approx. 9.930 kg to the machine weight.

SWING SYSTEM

Type..... Axial piston motor driving through planetary double reduction gearbox

Swing lock Electrically actuated wet multi-disc brake integrated into swing motor

Swing speed..... 0 - 9 rpm
 Swing torque 132 kNm

DRIVES AND BRAKES

Steering control 2 levers with pedals giving full independent control of each track

Drive method Hydrostatic

Travel operation Automatic 3-speed selection

Max. travel speeds
 Lo / Mi / Hi 3,0 / 4,4 / 5,5 km/h

Maximum drawbar pull.....34.000 kgf

Brake system..... Hydraulically operated discs in each travel motor

SERVICE REFILL CAPACITIES

Fuel tank 650 ltr
 Radiator 34 ltr
 Engine oil 38 ltr
 Swing drive 13,4 ltr
 Hydraulic tank 248 ltr
 Final drive (each side) 12 ltr

ENVIRONMENT

Engine emissions Fully complies with EU Stage IIIA and EPA Tier III exhaust emission regulations

Noise levels
 LwA external 107 dB(A) (2000/14/EC Stage II)
 LpA operator ear 71 dB(A) (ISO 6396 dynamic test)

Vibration levels (EN 12096:1997)*
 Hand/arm ≤ 2,5 m/s² (uncertainty K = 0,25 m/s²)
 Body ≤ 0,5 m/s² (uncertainty K = 0,10 m/s²)

* for the purpose of risk assessment under directive 2002/44/EC, please refer to ISO/TR 25398:2006.

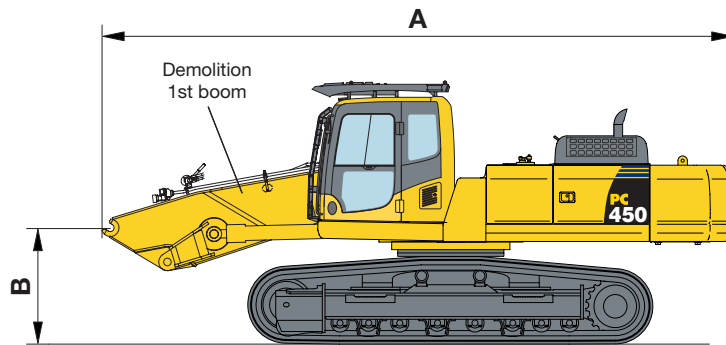

MACHINE DIMENSIONS

A	Transport length	8.315 mm
B	Maximum boom height (incl. hydraulic lines)	1.540 mm
	Transport weight with LC undercarriage (700 mm shoes, not including additional counterweight)	43.325 kg
	Additional weight for hydraulic wide gauge	9.930 kg
	Additional counterweight (1.470 mm × 640 mm × 550 mm)	4.490 kg

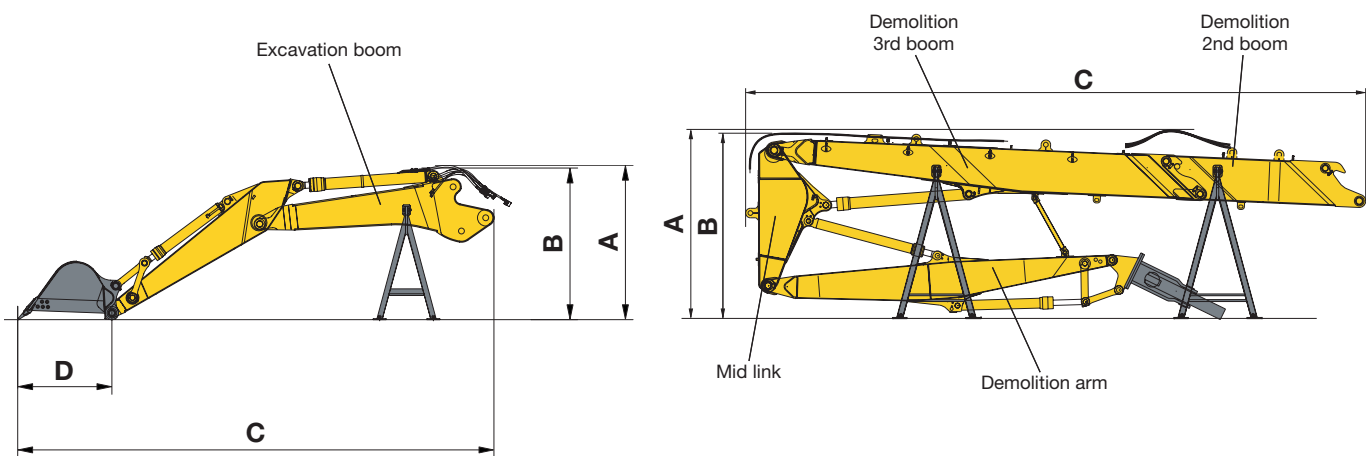

EQUIPMENT	EXCAVATION BOOM	HIGH REACH BOOM	
	2,9 m arm	3,4 m arm	
A	Total height (incl. hydraulic lines)	3.025 mm	3.425 mm
B	Height	2.980 mm	3.250 mm
C	Length	8.780 mm	11.412 mm
D	Tip radius	1.845 mm	–
	Support weight	320 kg	760 kg
	Excavation boom/2nd boom weight	2.910 kg ¹⁾	1.720 kg
	3rd boom weight ¹⁾	–	2.500 kg
	Mid link weight	–	1.050 kg
	Arm weight ¹⁾	2.295 kg	1.940 kg
	Bucket weight	2.180 kg	–
	Total weight ²⁾	7.705 kg	9.585 kg

1) Not including hydraulic cylinder.

2) Including hydraulic cylinders, links, hydraulic lines, stands and stated attachment weight.

Transport Dimensions

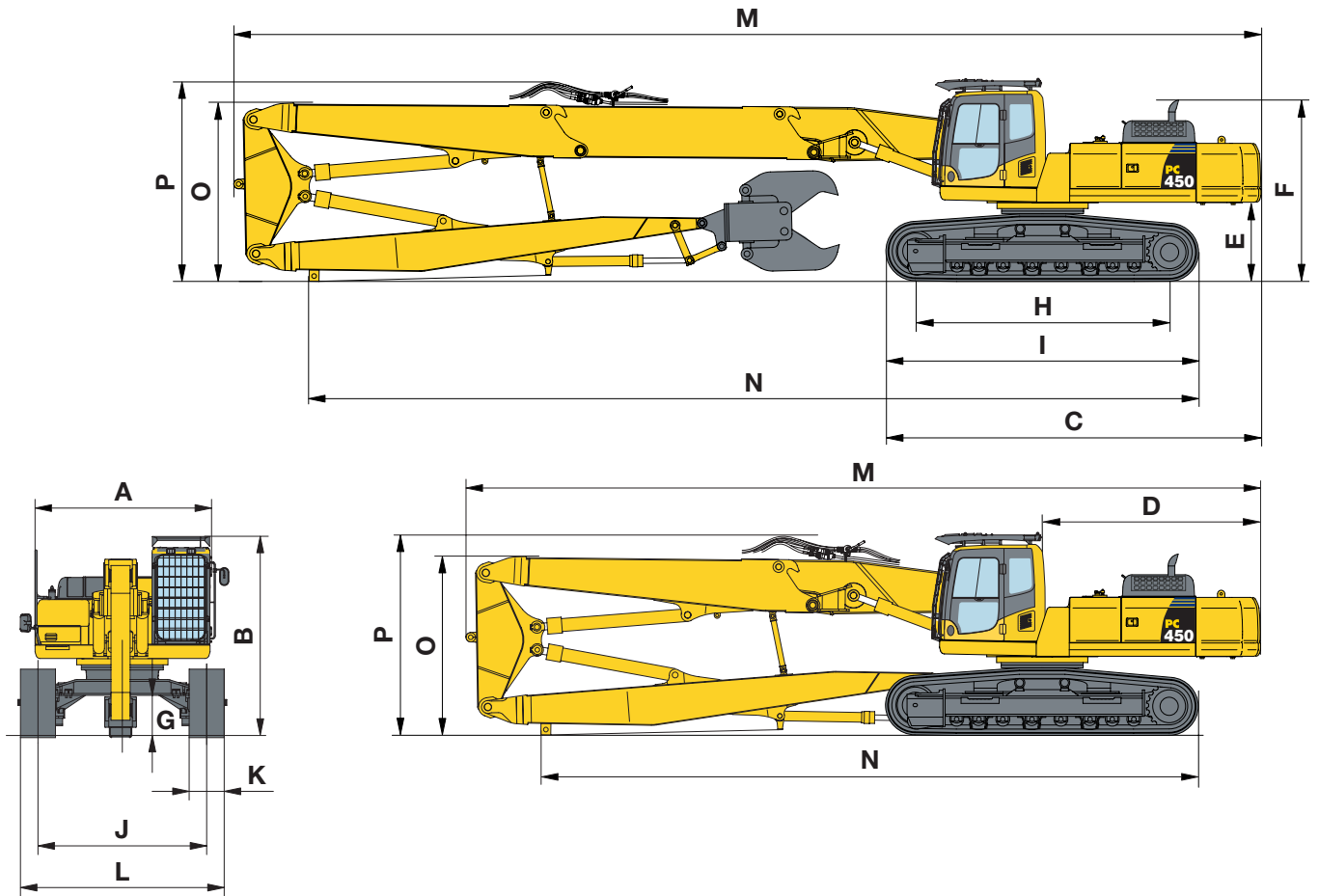

MACHINE DIMENSIONS	HIGH REACH	MEDIUM REACH
A Overall width of upper structure ¹⁾	2.995 mm	2.995 mm
B Overall height of cab, with FOPS ³⁾	3.485 mm	3.485 mm
Overall height of cab, without FOPS ³⁾	3.265 mm	3.265 mm
C Overall length of basic machine	6.385 mm	6.385 mm
D Tail length	3.705 mm	3.705 mm
E Clearance under counterweight	1.320 mm	1.320 mm
F Machine tail height	3.110 mm	3.110 mm
G Ground clearance	685 mm	685 mm
Ground clearance (HWG undercarriage)	500 mm	500 mm
H Tumbler centre distance	4.350 mm	4.350 mm
Tumbler centre distance (HWG undercarriage)	4.315 mm	4.315 mm
I Track length	5.355 mm	5.355 mm
J Track gauge ²⁾	2.390 - 2.890 mm	2.390 - 2.890 mm
Track gauge (HWG undercarriage)	2.280 - 3.130 mm	2.280 - 3.130 mm
K Track shoe width (700 mm only with HWG undercarriage)	600 mm, 700 mm	600 mm, 700 mm
L Overall track width with 600 mm shoes ²⁾	2.990 - 3.490 mm	2.990 - 3.490 mm
Overall track width with 700 mm shoes ²⁾	3.090 - 3.590 mm	3.090 - 3.590 mm
Overall track width with 700 mm shoes (HWG undercarriage) ²⁾	2.980 - 3.830 mm	2.980 - 3.830 mm
M Transport length	18.870 mm	14.870 mm
N Length on ground (transport)	17.840 mm	13.840 mm
O Overall height (to top of boom)	3.120 mm	3.110 mm
P Overall height (to top of hose)	3.350 mm	3.340 mm

1) Overall width of upper structure excludes side guards, handrails and mirrors. Side guards can be removed if transport width of less than 3 m is required.

2) Undercarriage in retracted - extended position

3) Overall height with Hydraulic Wide Gauge (HWG) undercarriage: + 165 mm

EXCAVATION BOOM - BENT POSITION

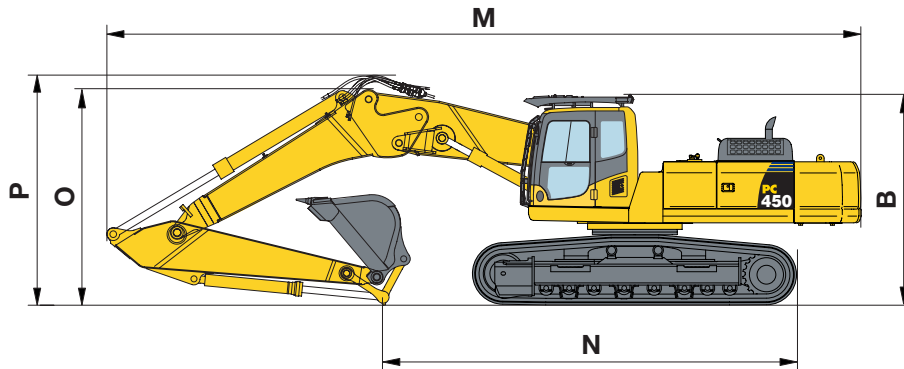

ARM LENGTH	2,9 m	3,4 m
M Overall transport length	12.555 mm	12.430 mm
N Transport length	7.415 mm	6.680 mm
B Transport height (to top of cab, with FOPS)	3.485 mm	3.485 mm
Transport height (to top of cab, without FOPS)	3.265 mm	3.265 mm
O Transport height (to top of boom)	3.880 mm	3.660 mm
P Transport height (to top of hose)	4.030 mm	3.810 mm

Overall height with Hydraulic Wide Gauge (HWG) undercarriage: + 165 mm

EXCAVATION BOOM - STRAIGHT POSITION

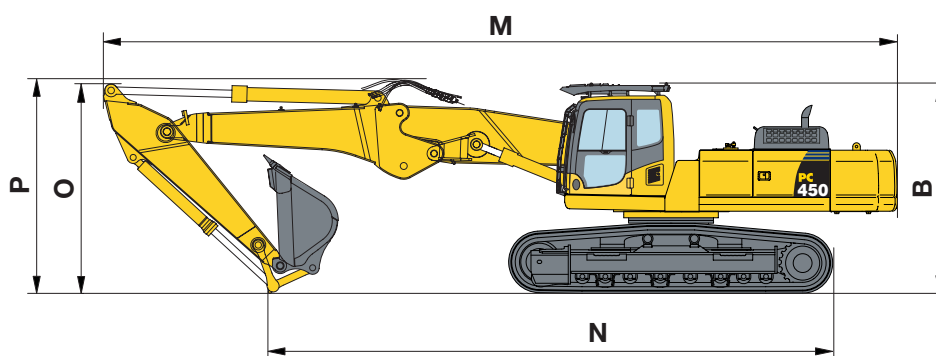

ARM LENGTH	2,9 m	3,4 m
M Overall transport length	13.095 mm	13.070 mm
N Transport length	9.105 mm	8.495 mm
B Transport height (to top of cab, with FOPS)	3.485 mm	3.485 mm
Transport height (to top of cab, without FOPS)	3.265 mm	3.265 mm
O Transport height (to top of boom)	3.620 mm	3.690 mm
P Transport height (to top of hose)	3.670 mm	3.740 mm

Overall height with Hydraulic Wide Gauge (HWG) undercarriage: + 165 mm

Working Range

HIGH REACH DEMOLITION

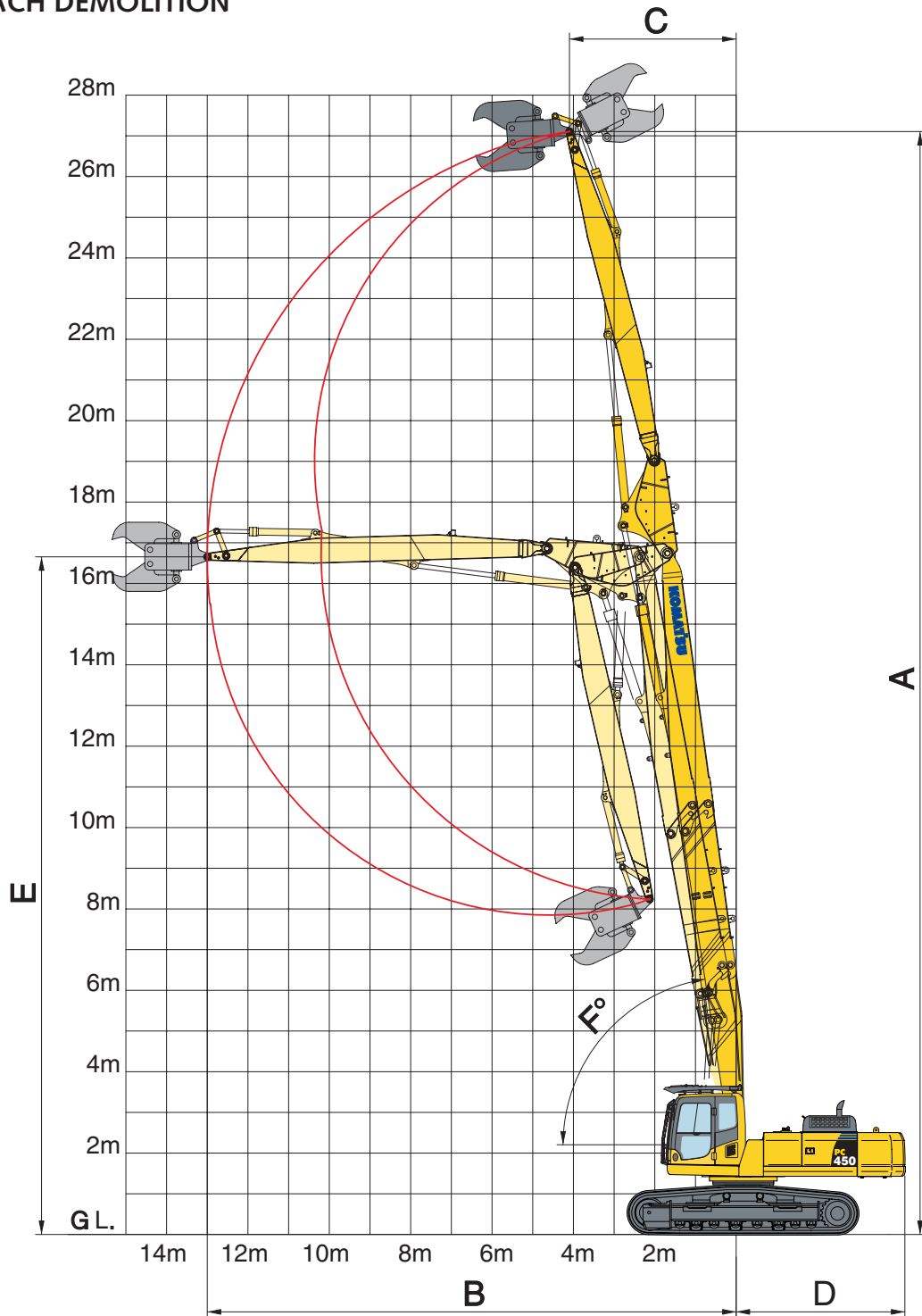

HIGH REACH DEMOLITION

A	Max. working height (to pin at arm end)	27.100 mm
B	Max. forward reach	13.500 mm
C	Min. swing radius of arm end pin (max. height)	4.100 mm
D	Tail swing radius	3.740 mm
E	Height at max. reach	16.650 mm
F	Min. boom angle from ground at max. height	80°

This working range is applicable through 360 degrees (depending upon fitted attachment) (for LC or HWG undercarriage). For operator and jobsite safety, Komatsu recommend that high reach demolition machines work in line with the trackframe where ever possible.

MEDIUM REACH DEMOLITION

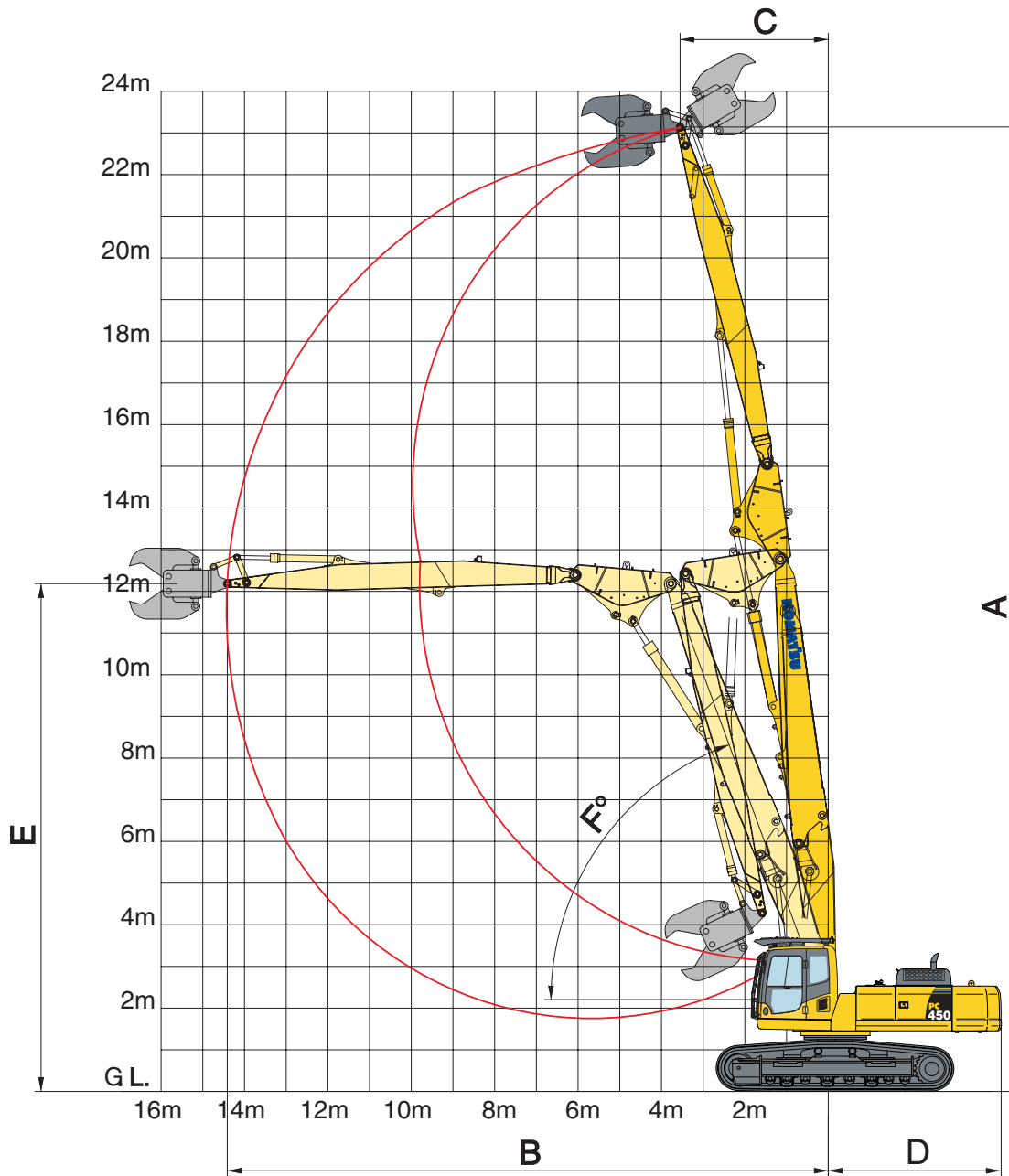

MEDIUM REACH DEMOLITION

A	Max. working height (to pin at arm end)	23.140 mm
B	Max. forward reach	14.410 mm
C	Min. swing radius of arm end pin (max. height)	3.550 mm
D	Tail swing radius	3.740 mm
E	Height at max. reach	12.180 mm
F	Min. boom angle from ground at max. height	70°

This working range is applicable through 360 degrees (depending upon fitted attachment) (for LC or HWG undercarriage). For operator and jobsite safety, Komatsu recommend that high reach demolition machines work in line with the trackframe where ever possible.

Working Range

EXCAVATION BOOM - BENT POSITION

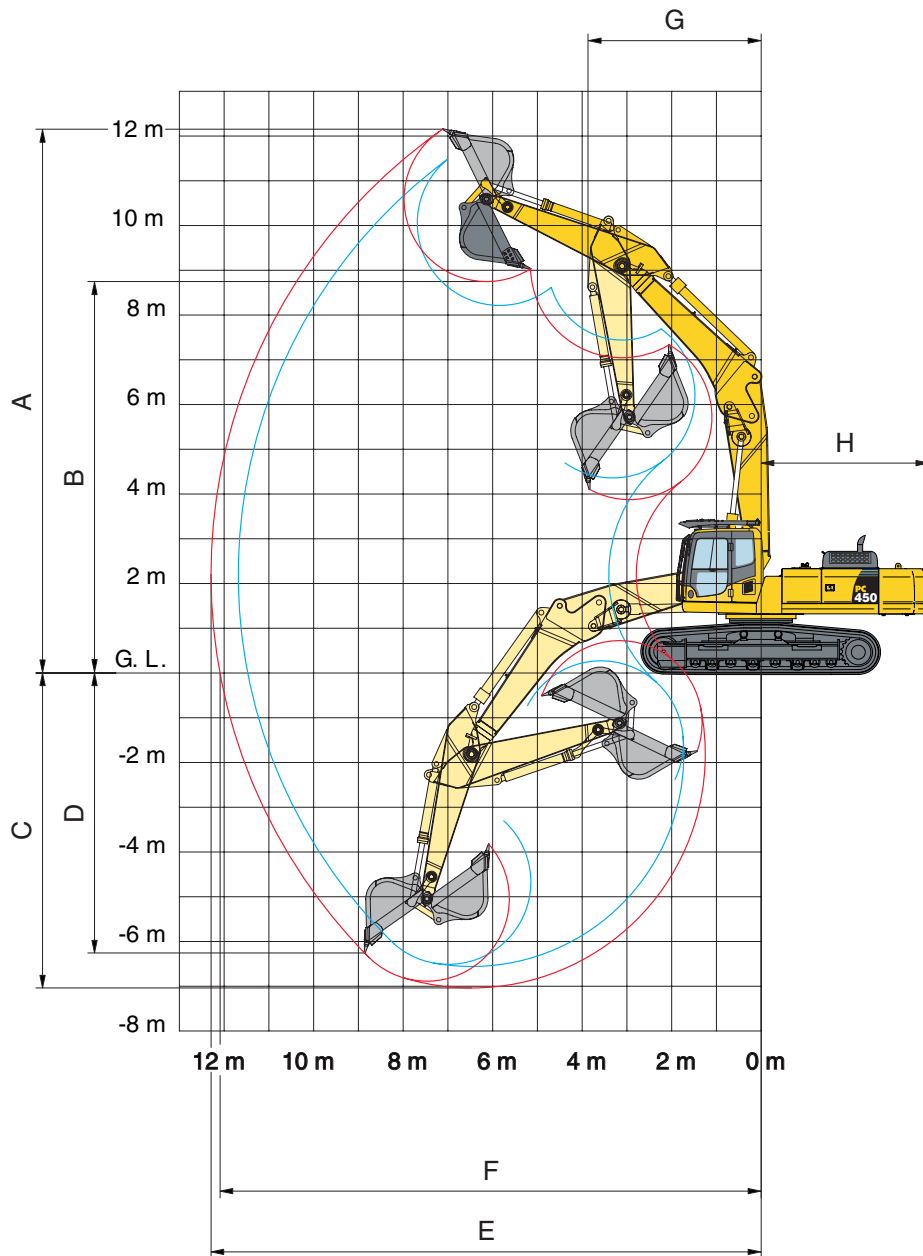

ARM LENGTH	2,9 m	3,4 m
A Max. digging height	11.470 mm	12.150 mm
B Max. dumping height	8.215 mm	8.750 mm
C Max. digging depth	6.555 mm	7.035 mm
D Max. vertical wall digging depth	5.060 mm	6.255 mm
E Max. digging reach	11.680 mm	12.290 mm
F Max. digging reach at ground level	11.470 mm	12.090 mm
G Min. swing radius (bucket loaded)	3.900 mm	3.870 mm
H Tail swing radius	3.740 mm	3.740 mm

EXCAVATION BOOM - STRAIGHT POSITION

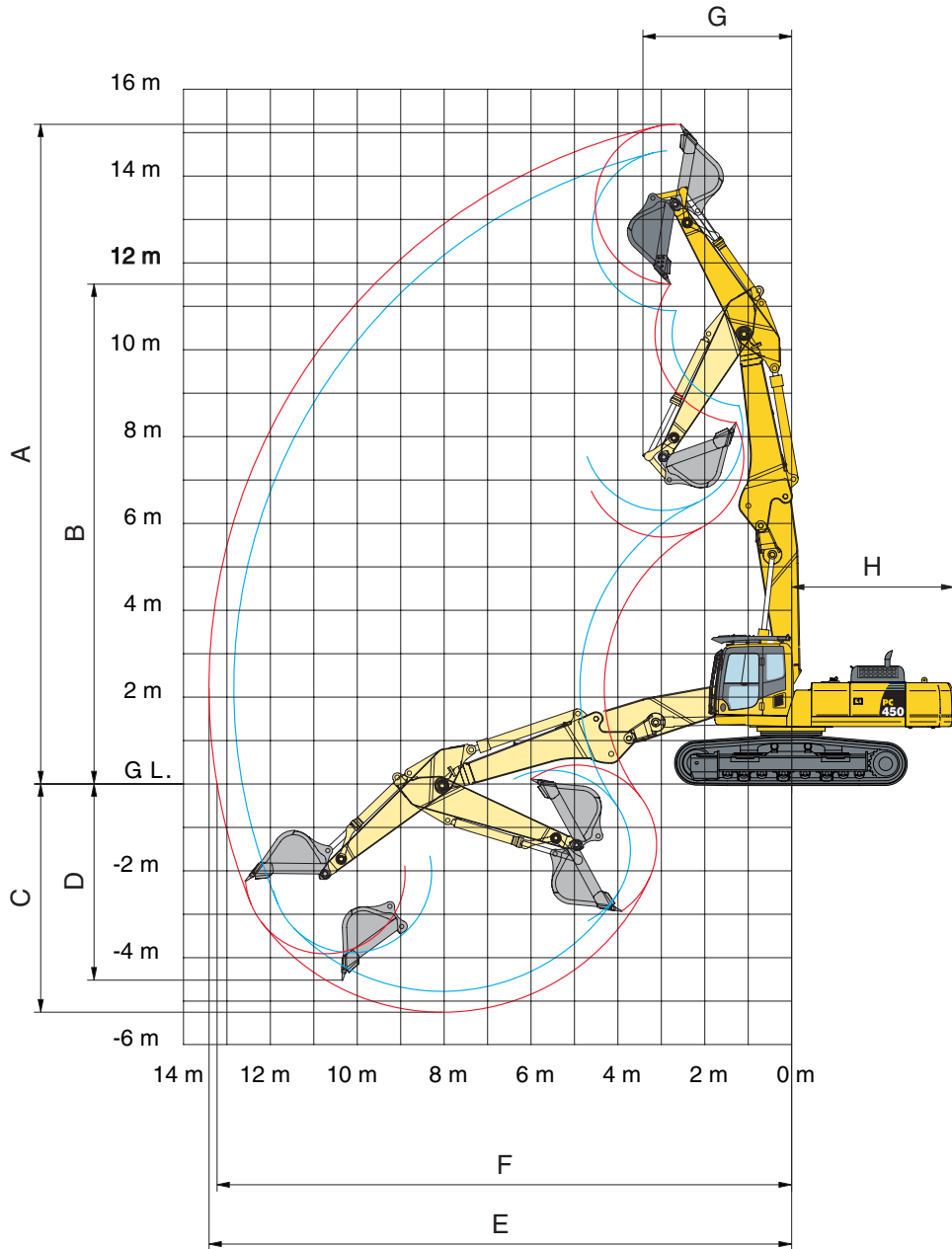

ARM LENGTH	2,9 m	3,4 m
A Max. digging height	14.580 mm	15.190 mm
B Max. dumping height	10.900 mm	11.510 mm
C Max. digging depth	4.775 mm	5.255 mm
D Max. vertical wall digging depth	4.045 mm	4.520 mm
E Max. digging reach	12.840 mm	13.410 mm
F Max. digging reach at ground level	12.645 mm	13.225 mm
G Min. swing radius (bucket loaded)	3.450 mm	3.425 mm
H Tail swing radius	3.740 mm	3.740 mm

Lifting Capacity

PC450LC-8

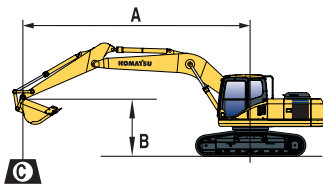

A – Reach from swing center

B – Bucket hook height

C – Lifting capacities, including bucket, bucket linkage and cylinder

– Rating over front

– Rating over side

– Rating at maximum reach

When removing bucket, linkage or cylinder, lifting capacities can be increased by their respective weights.

EXCAVATION BOOM - BENT POSITION

Arm length	A				10,5 m		9,0 m		7,5 m		6,0 m	
	B											
 2,9 m 1.914 kg	9,0 m	kg	10.250*	10.250*								
	7,5 m	kg	10.400*	8.400					12.900*	10.350		
	6,0 m	kg	10.950*	6.750			11.200	6.950	14.400*	9.900	17.000*	14.750
	4,5 m	kg	9.600	5.800			10.850	6.650	15.000	9.250	19.200*	13.450
	3,0 m	kg	8.900	5.250			10.450	6.250	14.200	8.550	20.500	12.100
	1,5 m	kg	8.600	5.000			10.050	5.900	13.450	7.900	19.250	11.000
	0,0 m	kg	8.750	5.000			9.750	5.600	13.000	7.500	18.550	10.400
	-1,5 m	kg	9.350	5.350			9.600	5.450	12.750	7.250	18.300	10.200
	-3,0 m	kg	10.750	6.150					12.500	7.050	18.400	10.250
	-4,5 m	kg	13.050*	7.900							15.850*	10.600
 3,4 m 1.914 kg	9,0 m	kg	7.050*	7.050*					8.000*	8.000*		
	7,5 m	kg	7.100*	7.100*					10.350*	10.350*		
	6,0 m	kg	7.400*	6.100			9.950*	7.150	13.050*	10.200	15.000*	15.000*
	4,5 m	kg	7.950*	5.300			11.050	6.800	15.050*	9.550	18.400*	13.950
	3,0 m	kg	8.200	4.850			10.600	6.400	14.500	8.800	20.450*	12.250
	1,5 m	kg	7.950	4.600			10.200	6.050	13.750	8.150	19.700	11.400
	0,0 m	kg	8.050	4.600			9.850	5.700	12.950	5.700	18.850	10.700
	-1,5 m	kg	8.500	4.850			9.650	5.500	12.850	7.350	18.450	10.350
	-3,0 m	kg	9.600	5.500			9.600	5.500	12.500	7.050	18.450	10.300
	-4,5 m	kg	11.850	6.850					12.950	7.450	17.350*	10.550

EXCAVATION BOOM - STRAIGHT POSITION

Arm length	A				10,5 m		9,0 m		7,5 m		6,0 m	
	B											
 2,9 m 1.914 kg	9,0 kg	kg	10.450*	6.950					12.900*	10.000	12.750*	12.750*
	7,5 kg	kg	9.100	5.450			10.950	6.750	14.350*	9.700	14.350*	14.350*
	6,0 kg	kg	7.850	4.550	7.900	4.600	10.700	6.500	14.900	9.150	21.150*	13.500
	4,5 kg	kg	7.150	4.050	7.750	4.450	10.300	6.150	14.100	8.450	20.100	11.750
	3,0 kg	kg	6.750	3.750	7.550	4.300	9.850	5.750	13.200	7.700	18.950	10.750
	1,5 kg	kg	6.600	3.600	7.350	4.100	9.500	5.400	12.650	7.200	17.950	9.900
	0,0 kg	kg	6.750	3.700	7.250	4.000	9.250	5.200	12.300	6.850	17.600	9.600
	-1,5 kg	kg	7.200	3.950	7.250	4.000	9.200	5.100	12.200	6.800	15.850*	9.600
	-3,0 kg	kg					8.400*	5.200	10.600*	6.900		
	 3,4 m 1.914 kg	9,0 kg	kg	7.300*	6.050			8.900*	7.000	10.000*	10.000*	9.700*
7,5 kg		kg	7.150*	4.850			10.400*	6.950	10.950*	10.000	10.600*	10.600*
6,0 kg		kg	7.200	4.150	8.100	4.800	10.900	6.700	13.600*	9.450	15.200*	13.950
4,5 kg		kg	6.550	3.700	7.900	4.600	10.500	6.300	14.400	8.750	21.100	12.600
3,0 kg		kg	6.250	3.450	7.700	4.400	10.050	5.900	13.550	8.000	19.500	11.200
1,5 kg		kg	6.150	3.350	7.450	4.200	9.650	5.550	12.900	7.400	18.350	10.250
0,0 kg		kg	6.250	3.400	7.300	4.050	9.350	5.250	12.450	7.000	17.800	9.800
-1,5 kg		kg	6.600	3.600	7.250	4.000	9.200	5.150	12.300	6.850	17.400*	9.700
-3,0 kg		kg	6.350*	4.050	6.450*	4.050	9.250	5.150	11.850*	6.900	13.600*	9.850

Lifting capacity table is published for guidance only, the machine is not intended for use as a crane. Lifting capacities are stated in kg, on the tip of the arm, for machine on firm, level supporting surface. The weight of any attachment used should be deducted from the values shown, to calculate payload. Indicated loads are based on ISO 10567 standard and do not exceed 75% of tipping or 87% of hydraulic capacity (indicated by *). Lifting capacity of the machine is limited by machine stability, hydraulic capacity and maximum permissible load of the attachment.

Standard and Optional Equipment

ENGINE

Komatsu SAA6D125E-5, 263 kW turbocharged common rail direct injection diesel engine	●
EU Stage IIIA compliant	
Suction type cooling fan with radiator fly screen	●
Automatic engine warm-up system	●
Engine overheat prevention system	●
Fuel control dial	●
Auto-deceleration function	●
Engine key stop	●
Engine ignition can be password secured on request	●
Alternator 24 V/60 A	●
Starter motor 24 V/11 kW	●
Batteries 2 × 12 V/140 Ah	●

HYDRAULIC SYSTEM

Electronic closed-centre load sensing (E-CLSS) hydraulic system (HydrauMind)	●
Pump and engine mutual control (PEMC) system	●
5-working mode selection system; power mode, economy mode, breaker mode, attachment mode and lifting mode	●
PowerMax function	●
Adjustable PPC wrist control levers for arm, boom, bucket and swing, with sliding proportional control for attachments and 3 auxiliary buttons	●
In-line filter for hydraulics	●
Two additional service valves (full flow)	●
One additional service valve (1/2 flow)	●
Drain circuit for hydraulic attachment rotation motors	●

UNDERCARRIAGE

Track roller guards	●
Track frame under-guards	●
LC or hydraulic adjustable wide gauge (HWG) undercarriage	○
600, 700 mm triple grouser track shoes (HWG: 700 mm only)	○
Full length track roller guards (not HWG)	○

SERVICE AND MAINTENANCE

Automatic fuel line de-aeration	●
Double element type air cleaner with dust indicator and auto dust evacuator	●
KOMTRAX™ - Komatsu satellite monitoring system	●
Multi-function video compatible colour monitor with Equipment Management and Monitoring System (EMMS) and efficiency guidance	●
Toolkit and spare parts for first service	●
Service points	○

CABIN

Demolition Safety SpaceCab™, with ISO 10262 level 2 FOPS guards and roof screen wash/wiper, safety glass windows, pull-up type front window with locking device, fixed roof window with wiper and washer, removable lower window, front window wiper	●
Tilting cab, with control equipment, hydraulic power hoses and cab raise cylinders	●
Heated air suspension seat with lumbar support, height adjustable arm rests and retractable seat belt	●
Automatic climate control system	●
12 Volt power supply	●
Beverage holder and magazine rack	●
Hot and cool box	●
Radio	●

WORK EQUIPMENT

Demolition first boom: Includes demolition first boom, fitted with hydraulic pipework, with quick connectors, suitable for operation of high reach demolition work equipment and operation of rotating crusher attachment	●
Two-mode boom control	●
Excavation arm assemblies: Includes bucket cylinder and piping, bucket linkage, 2,9 m or 3,4 m standard arm, with 2 additional dual flow proportional service circuits, with drain circuit for hydraulic attachment rotation motors	○
Excavation boom: Includes two position excavation boom (bent/straight) to fit onto demolition first boom. Associated pipework for excavation arm cylinder and bucket cylinder. Quick connectors to suit demolition first boom. With pipework suitable for operation of excavation equipment and rotating crusher attachment (includes pipework associated with excavation boom)	○
Demolition second boom: Includes demolition extension boom (4,0 m) fitted with hydraulic pipework, with quick connectors, suitable for operation of high reach demolition work equipment and operation of rotating crusher attachment	○
Demolition third boom: Includes demolition third boom, mid link, high reach demolition arm, demolition attachment linkage. Fitted with hydraulic pipework, with quick connectors, suitable for operation of high reach demolition work equipment and operation of rotating crusher attachment	○
Komatsu buckets	○

SAFETY EQUIPMENT

Rear view camera system	●
Electric horn	●
Overload warning device	●
Lockable fuel cap and covers	●
Audible travel alarm	●
Boom safety valves	●
Large handrails, r.h. rear-view mirror	●
Battery main switch	●

DRIVES AND BRAKES

Hydrostatic, 3-speed travel system with automatic shift and planetary gear type final drives, and hydraulic travel and parking brakes	●
PPC control levers and pedals for steering and travel	●
PPC pedal for high reach demolition mid link	●

LIGHTING SYSTEM

Working lights: 2 revolving frame lights and 1 boom light, 4 cab roof (front) lights, 1 cab roof (rear) light, 1 counterweight (rear) light	●
---	---

OTHER EQUIPMENT

Heavy duty revolving frame with heavy duty demolition under covers and side guard protection	●
Counterweight prepared for demolition counterweight	●
Remote greasing for swing circle and pins	●
Electric refuelling pump with automatic shut off function	●
Standard colour scheme and decals	●
Parts book and operator manual	●
Additional counterweight. To fit into main demolition counterweight when high reach demolition equipment is installed. Removable for excavation operations. Included with any high reach boom equipment	○
Biodegradable oil for hydraulic system	○
Customised paint	○

Further equipment on request

- standard equipment
- optional equipment

Hydraulic Excavator

PC450LC-8

High Reach Demolition Specification

Your Komatsu partner:

KOMATSU

**Komatsu Europe
International NV**

Mechelsesteenweg 586
B-1800 VILVOORDE (BELGIUM)

Tel. +32-2-255 24 11

Fax +32-2-252 19 81

www.komatsu.eu

UESS13503 09/2010

Materials and specifications are subject to change without notice.

KOMATSU is a trademark of Komatsu Ltd. Japan.